



Instruction
Harmony Series

Field Bus Termination Unit NTFB01



Preface



The NTFB01 Field Bus Termination Unit is a Harmony rack I/O device that is part of the Symphony Enterprise Management and Control System. It provides a communication link between 15 frequency shift keyed smart transmitters (or other smart devices) and an IMFEC11 Analog Input Module functioning in frequency shift keyed (FSK) field bus mode.

This instruction explains the NTFB01 termination unit specifications and operation. It details the procedures necessary to complete setup, installation, maintenance, repair, and replacement of the termination unit.

NOTE: The NTFB01 termination unit is fully compatible with existing INFI 90® OPEN Strategic Enterprise Management Systems.



List of Effective Pages

Total number of pages in this instruction is 30, consisting of the following:

Page No.	Change Date
Preface	Original
List of Effective Pages	Original
iii through viii	Original
1-1 through 1-5	Original
2-1 through 2-10	Original
3-1 through 3-4	Original
4-1 through 4-2	Original
Index-1	Original

NOTE: Changed text or tables are indicated by a vertical bar adjacent to the changed area. Changed figures are indicated by a vertical bar next to the figure caption. The date appears beside the page number.

Table of Contents



Section 1 Introduction	1-1
Overview	1-1
Intended User	1-2
Description	1-2
Mounting Hardware	1-2
Instruction Content.....	1-2
How to Use this Instruction	1-3
Document Conventions	1-3
Reference Documents.....	1-4
Related Nomenclature	1-4
Specifications.....	1-5
Section 2 Installation	2-1
Introduction.....	2-1
Special Handling.....	2-1
Unpacking and Inspection.....	2-2
Setup/Physical Installation	2-2
Mounting	2-2
Cable Connection	2-4
Power Wiring.....	2-5
Terminal Block Wiring	2-5
Star Field Bus	2-5
Linear Field Bus	2-6
Maximum Field Bus Length	2-7
Installation Complete	2-9
Section 3 Maintenance	3-1
Introduction.....	3-1
Preventive Maintenance Schedule.....	3-1
Equipment and Tools Required.....	3-1
Preventive Maintenance Procedures.....	3-2
Printed Circuit Board Cleaning	3-2
General Cleaning and Washing	3-3
Edge Connector Cleaning.....	3-3
Checking Connections.....	3-4
Section 4 Repair and Replacement	4-1
Introduction.....	4-1
Termination Unit Replacement	4-1



List of Figures

<i>No.</i>	<i>Title</i>	<i>Page</i>
1-1.	Harmony Rack I/O Architecture	1-1
1-2.	Mounting Hardware	1-3
2-1.	Termination Unit Installation	2-3
2-2.	Termination Unit Layout (Upper Circuit Board)	2-3
2-3.	Cable Connection	2-4
2-4.	Star Field Bus Connections	2-6
2-5.	Linear Field Bus Connections	2-6
2-6.	Maximum Total Field Bus Length (for Field Bus Module Communication)	2-7
2-7.	Maximum Total Field Bus Length (for STT02 Transmitter Communication)	2-8
2-8.	Example Star Field Bus	2-9
2-9.	Example Star and Linear Field Bus Combination	2-10

List of Tables

<i>No.</i>	<i>Title</i>	<i>Page</i>
1-1.	Reference Documents	1-4
1-2.	Related Nomenclature	1-4
1-3.	NTFB01 Termination Unit Specifications	1-5
3-1.	Preventive Maintenance Schedule	3-2
4-1.	Parts List	4-1

Safety Summary



Electrostatic Sensitive Device

Devices labeled with this symbol require special handling precautions as described in the installation section.

GENERAL WARNINGS

Equipment Environment

All components, whether in transportation, operation or storage, must be in a noncorrosive environment.

Electrical Shock Hazard During Maintenance

Disconnect power or take precautions to insure that contact with energized parts is avoided when servicing.

SPECIFIC WARNINGS

Verify the main power, field power, and power entry panel circuit breakers/switches are turned off before starting installation, retrofit, upgrade, or wiring procedures. Failure to do so could result in severe or fatal shock. Do not turn the power on until the installation, retrofit, upgrade, or wiring procedures are complete. (p. 2-5)

Never clean electrical parts or components with live power present. Doing so exposes you to an electrical shock hazard. (p. 3-2)

Wear eye protection whenever working with cleaning solvents. When removing solvents from printed circuit boards using compressed air, injury to the eyes could result from splashing solvent as it is removed from the printed circuit board. (p. 3-2)

There are exposed AC and DC connections inside the cabinet. These exposed electrical connections present a shock hazard that can cause injury or death. (p. 3-4)

If input or output circuits are a shock hazard after disconnecting system power at the power entry panel, then the door of the cabinet containing these externally powered circuits must be marked with a warning stating that multiple power sources exist. (p. 3-4)



Safety Summary (continued)

SPECIFIC CAUTIONS	Remove a module from its assigned slot before installing or removing a cable assigned to that slot. Failure to do so could result in damage to the module. (p. 2-4, 4-1)
------------------------------	--

Support Services



ABB will provide assistance in the operation and repair of its products. Requests for sales or application services should be made to your nearest sales or service office. ABB can also provide installation, repair and maintenance contract services.

When ordering parts, use nomenclature or part numbers and part descriptions from equipment manuals. Parts without a description must be ordered from the nearest sales or service office. Recommended spare parts lists, including prices are available through the nearest sales or service office.

ABB has modern training facilities available for training your personnel. On-site training is also available. Contact your nearest ABB sales office for specific information and scheduling.

Additional copies of this instruction, or other instructions, can be obtained from the nearest ABB sales office at a reasonable charge.



Trademarks and Registrations

Registrations and trademarks used in this document include:

® INFI 90 Registered trademark of Elsig Bailey Process Automation.

Preface



The NTFB01 Field Bus Termination Unit is a Harmony rack I/O device that is part of the Symphony Enterprise Management and Control System. It provides a communication link between 15 frequency shift keyed smart transmitters (or other smart devices) and an IMFEC11 Analog Input Module functioning in frequency shift keyed (FSK) field bus mode.

This instruction explains the NTFB01 termination unit specifications and operation. It details the procedures necessary to complete setup, installation, maintenance, repair, and replacement of the termination unit.

NOTE: The NTFB01 termination unit is fully compatible with existing INFI 90® OPEN Strategic Enterprise Management Systems.



List of Effective Pages

Total number of pages in this instruction is 30, consisting of the following:

Page No.	Change Date
Preface	Original
List of Effective Pages	Original
iii through viii	Original
1-1 through 1-5	Original
2-1 through 2-10	Original
3-1 through 3-4	Original
4-1 through 4-2	Original
Index-1	Original

NOTE: Changed text or tables are indicated by a vertical bar adjacent to the changed area. Changed figures are indicated by a vertical bar next to the figure caption. The date appears beside the page number.

Table of Contents



Section 1 Introduction	1-1
Overview	1-1
Intended User	1-2
Description	1-2
Mounting Hardware	1-2
Instruction Content.....	1-2
How to Use this Instruction	1-3
Document Conventions	1-3
Reference Documents.....	1-4
Related Nomenclature	1-4
Specifications.....	1-5
Section 2 Installation	2-1
Introduction.....	2-1
Special Handling.....	2-1
Unpacking and Inspection.....	2-2
Setup/Physical Installation	2-2
Mounting	2-2
Cable Connection	2-4
Power Wiring.....	2-5
Terminal Block Wiring	2-5
Star Field Bus	2-5
Linear Field Bus	2-6
Maximum Field Bus Length	2-7
Installation Complete	2-9
Section 3 Maintenance	3-1
Introduction.....	3-1
Preventive Maintenance Schedule.....	3-1
Equipment and Tools Required.....	3-1
Preventive Maintenance Procedures.....	3-2
Printed Circuit Board Cleaning	3-2
General Cleaning and Washing	3-3
Edge Connector Cleaning.....	3-3
Checking Connections.....	3-4
Section 4 Repair and Replacement	4-1
Introduction.....	4-1
Termination Unit Replacement	4-1



List of Figures

No.	Title	Page
1-1.	Harmony Rack I/O Architecture	1-1
1-2.	Mounting Hardware	1-3
2-1.	Termination Unit Installation	2-3
2-2.	Termination Unit Layout (Upper Circuit Board)	2-3
2-3.	Cable Connection	2-4
2-4.	Star Field Bus Connections	2-6
2-5.	Linear Field Bus Connections	2-6
2-6.	Maximum Total Field Bus Length (for Field Bus Module Communication)	2-7
2-7.	Maximum Total Field Bus Length (for STT02 Transmitter Communication)	2-8
2-8.	Example Star Field Bus	2-9
2-9.	Example Star and Linear Field Bus Combination	2-10

List of Tables

No.	Title	Page
1-1.	Reference Documents	1-4
1-2.	Related Nomenclature	1-4
1-3.	NTFB01 Termination Unit Specifications	1-5
3-1.	Preventive Maintenance Schedule	3-2
4-1.	Parts List	4-1

Safety Summary



Electrostatic Sensitive Device

Devices labeled with this symbol require special handling precautions as described in the installation section.

GENERAL WARNINGS

Equipment Environment

All components, whether in transportation, operation or storage, must be in a noncorrosive environment.

Electrical Shock Hazard During Maintenance

Disconnect power or take precautions to insure that contact with energized parts is avoided when servicing.

SPECIFIC WARNINGS

Verify the main power, field power, and power entry panel circuit breakers/switches are turned off before starting installation, retrofit, upgrade, or wiring procedures. Failure to do so could result in severe or fatal shock. Do not turn the power on until the installation, retrofit, upgrade, or wiring procedures are complete. (p. 2-5)

Never clean electrical parts or components with live power present. Doing so exposes you to an electrical shock hazard. (p. 3-2)

Wear eye protection whenever working with cleaning solvents. When removing solvents from printed circuit boards using compressed air, injury to the eyes could result from splashing solvent as it is removed from the printed circuit board. (p. 3-2)

There are exposed AC and DC connections inside the cabinet. These exposed electrical connections present a shock hazard that can cause injury or death. (p. 3-4)

If input or output circuits are a shock hazard after disconnecting system power at the power entry panel, then the door of the cabinet containing these externally powered circuits must be marked with a warning stating that multiple power sources exist. (p. 3-4)



Safety Summary (continued)

SPECIFIC CAUTIONS	Remove a module from its assigned slot before installing or removing a cable assigned to that slot. Failure to do so could result in damage to the module. (p. 2-4, 4-1)
--------------------------	--

Support Services



ABB will provide assistance in the operation and repair of its products. Requests for sales or application services should be made to your nearest sales or service office. ABB can also provide installation, repair and maintenance contract services.

When ordering parts, use nomenclature or part numbers and part descriptions from equipment manuals. Parts without a description must be ordered from the nearest sales or service office. Recommended spare parts lists, including prices are available through the nearest sales or service office.

ABB has modern training facilities available for training your personnel. On-site training is also available. Contact your nearest ABB sales office for specific information and scheduling.

Additional copies of this instruction, or other instructions, can be obtained from the nearest ABB sales office at a reasonable charge.



Trademarks and Registrations

Registrations and trademarks used in this document include:

® INFI 90

Registered trademark of Elsig Bailey Process Automation.

Preface



The NTFB01 Field Bus Termination Unit is a Harmony rack I/O device that is part of the Symphony Enterprise Management and Control System. It provides a communication link between 15 frequency shift keyed smart transmitters (or other smart devices) and an IMFEC11 Analog Input Module functioning in frequency shift keyed (FSK) field bus mode.

This instruction explains the NTFB01 termination unit specifications and operation. It details the procedures necessary to complete setup, installation, maintenance, repair, and replacement of the termination unit.

NOTE: The NTFB01 termination unit is fully compatible with existing INFI 90® OPEN Strategic Enterprise Management Systems.



List of Effective Pages

Total number of pages in this instruction is 30, consisting of the following:

Page No.	Change Date
Preface	Original
List of Effective Pages	Original
iii through viii	Original
1-1 through 1-5	Original
2-1 through 2-10	Original
3-1 through 3-4	Original
4-1 through 4-2	Original
Index-1	Original

NOTE: Changed text or tables are indicated by a vertical bar adjacent to the changed area. Changed figures are indicated by a vertical bar next to the figure caption. The date appears beside the page number.

Table of Contents



Section 1 Introduction	1-1
Overview	1-1
Intended User	1-2
Description	1-2
Mounting Hardware	1-2
Instruction Content.....	1-2
How to Use this Instruction	1-3
Document Conventions	1-3
Reference Documents.....	1-4
Related Nomenclature	1-4
Specifications.....	1-5
Section 2 Installation	2-1
Introduction.....	2-1
Special Handling.....	2-1
Unpacking and Inspection.....	2-2
Setup/Physical Installation	2-2
Mounting	2-2
Cable Connection	2-4
Power Wiring.....	2-5
Terminal Block Wiring	2-5
Star Field Bus	2-5
Linear Field Bus	2-6
Maximum Field Bus Length	2-7
Installation Complete	2-9
Section 3 Maintenance	3-1
Introduction.....	3-1
Preventive Maintenance Schedule.....	3-1
Equipment and Tools Required.....	3-1
Preventive Maintenance Procedures.....	3-2
Printed Circuit Board Cleaning	3-2
General Cleaning and Washing	3-3
Edge Connector Cleaning.....	3-3
Checking Connections.....	3-4
Section 4 Repair and Replacement	4-1
Introduction.....	4-1
Termination Unit Replacement	4-1



List of Figures

<i>No.</i>	<i>Title</i>	<i>Page</i>
1-1.	Harmony Rack I/O Architecture	1-1
1-2.	Mounting Hardware	1-3
2-1.	Termination Unit Installation	2-3
2-2.	Termination Unit Layout (Upper Circuit Board)	2-3
2-3.	Cable Connection	2-4
2-4.	Star Field Bus Connections	2-6
2-5.	Linear Field Bus Connections	2-6
2-6.	Maximum Total Field Bus Length (for Field Bus Module Communication)	2-7
2-7.	Maximum Total Field Bus Length (for STT02 Transmitter Communication)	2-8
2-8.	Example Star Field Bus	2-9
2-9.	Example Star and Linear Field Bus Combination	2-10

List of Tables

<i>No.</i>	<i>Title</i>	<i>Page</i>
1-1.	Reference Documents	1-4
1-2.	Related Nomenclature	1-4
1-3.	NTFB01 Termination Unit Specifications	1-5
3-1.	Preventive Maintenance Schedule	3-2
4-1.	Parts List	4-1

Safety Summary



Electrostatic Sensitive Device

Devices labeled with this symbol require special handling precautions as described in the installation section.

GENERAL WARNINGS

Equipment Environment

All components, whether in transportation, operation or storage, must be in a noncorrosive environment.

Electrical Shock Hazard During Maintenance

Disconnect power or take precautions to insure that contact with energized parts is avoided when servicing.

SPECIFIC WARNINGS

Verify the main power, field power, and power entry panel circuit breakers/switches are turned off before starting installation, retrofit, upgrade, or wiring procedures. Failure to do so could result in severe or fatal shock. Do not turn the power on until the installation, retrofit, upgrade, or wiring procedures are complete. (p. 2-5)

Never clean electrical parts or components with live power present. Doing so exposes you to an electrical shock hazard. (p. 3-2)

Wear eye protection whenever working with cleaning solvents. When removing solvents from printed circuit boards using compressed air, injury to the eyes could result from splashing solvent as it is removed from the printed circuit board. (p. 3-2)

There are exposed AC and DC connections inside the cabinet. These exposed electrical connections present a shock hazard that can cause injury or death. (p. 3-4)

If input or output circuits are a shock hazard after disconnecting system power at the power entry panel, then the door of the cabinet containing these externally powered circuits must be marked with a warning stating that multiple power sources exist. (p. 3-4)



Safety Summary (continued)

SPECIFIC CAUTIONS	Remove a module from its assigned slot before installing or removing a cable assigned to that slot. Failure to do so could result in damage to the module. (p. 2-4, 4-1)
------------------------------	--

Support Services



ABB will provide assistance in the operation and repair of its products. Requests for sales or application services should be made to your nearest sales or service office. ABB can also provide installation, repair and maintenance contract services.

When ordering parts, use nomenclature or part numbers and part descriptions from equipment manuals. Parts without a description must be ordered from the nearest sales or service office. Recommended spare parts lists, including prices are available through the nearest sales or service office.

ABB has modern training facilities available for training your personnel. On-site training is also available. Contact your nearest ABB sales office for specific information and scheduling.

Additional copies of this instruction, or other instructions, can be obtained from the nearest ABB sales office at a reasonable charge.



Trademarks and Registrations

Registrations and trademarks used in this document include:

® INFI 90 Registered trademark of Elsig Bailey Process Automation.

Preface



The NTFB01 Field Bus Termination Unit is a Harmony rack I/O device that is part of the Symphony Enterprise Management and Control System. It provides a communication link between 15 frequency shift keyed smart transmitters (or other smart devices) and an IMFEC11 Analog Input Module functioning in frequency shift keyed (FSK) field bus mode.

This instruction explains the NTFB01 termination unit specifications and operation. It details the procedures necessary to complete setup, installation, maintenance, repair, and replacement of the termination unit.

NOTE: The NTFB01 termination unit is fully compatible with existing INFI 90® OPEN Strategic Enterprise Management Systems.



List of Effective Pages

Total number of pages in this instruction is 30, consisting of the following:

Page No.	Change Date
Preface	Original
List of Effective Pages	Original
iii through viii	Original
1-1 through 1-5	Original
2-1 through 2-10	Original
3-1 through 3-4	Original
4-1 through 4-2	Original
Index-1	Original

NOTE: Changed text or tables are indicated by a vertical bar adjacent to the changed area. Changed figures are indicated by a vertical bar next to the figure caption. The date appears beside the page number.

Table of Contents



Section 1 Introduction	1-1
Overview	1-1
Intended User	1-2
Description	1-2
Mounting Hardware	1-2
Instruction Content.....	1-2
How to Use this Instruction	1-3
Document Conventions	1-3
Reference Documents.....	1-4
Related Nomenclature	1-4
Specifications.....	1-5
Section 2 Installation	2-1
Introduction.....	2-1
Special Handling.....	2-1
Unpacking and Inspection.....	2-2
Setup/Physical Installation	2-2
Mounting	2-2
Cable Connection	2-4
Power Wiring.....	2-5
Terminal Block Wiring	2-5
Star Field Bus	2-5
Linear Field Bus	2-6
Maximum Field Bus Length	2-7
Installation Complete	2-9
Section 3 Maintenance	3-1
Introduction.....	3-1
Preventive Maintenance Schedule.....	3-1
Equipment and Tools Required.....	3-1
Preventive Maintenance Procedures.....	3-2
Printed Circuit Board Cleaning	3-2
General Cleaning and Washing	3-3
Edge Connector Cleaning.....	3-3
Checking Connections.....	3-4
Section 4 Repair and Replacement	4-1
Introduction.....	4-1
Termination Unit Replacement	4-1



List of Figures

No.	Title	Page
1-1.	Harmony Rack I/O Architecture	1-1
1-2.	Mounting Hardware	1-3
2-1.	Termination Unit Installation	2-3
2-2.	Termination Unit Layout (Upper Circuit Board)	2-3
2-3.	Cable Connection	2-4
2-4.	Star Field Bus Connections	2-6
2-5.	Linear Field Bus Connections	2-6
2-6.	Maximum Total Field Bus Length (for Field Bus Module Communication)	2-7
2-7.	Maximum Total Field Bus Length (for STT02 Transmitter Communication)	2-8
2-8.	Example Star Field Bus	2-9
2-9.	Example Star and Linear Field Bus Combination	2-10

List of Tables

No.	Title	Page
1-1.	Reference Documents	1-4
1-2.	Related Nomenclature	1-4
1-3.	NTFB01 Termination Unit Specifications	1-5
3-1.	Preventive Maintenance Schedule	3-2
4-1.	Parts List	4-1

Safety Summary



Electrostatic Sensitive Device

Devices labeled with this symbol require special handling precautions as described in the installation section.

GENERAL WARNINGS

Equipment Environment

All components, whether in transportation, operation or storage, must be in a noncorrosive environment.

Electrical Shock Hazard During Maintenance

Disconnect power or take precautions to insure that contact with energized parts is avoided when servicing.

SPECIFIC WARNINGS

Verify the main power, field power, and power entry panel circuit breakers/switches are turned off before starting installation, retrofit, upgrade, or wiring procedures. Failure to do so could result in severe or fatal shock. Do not turn the power on until the installation, retrofit, upgrade, or wiring procedures are complete. (p. 2-5)

Never clean electrical parts or components with live power present. Doing so exposes you to an electrical shock hazard. (p. 3-2)

Wear eye protection whenever working with cleaning solvents. When removing solvents from printed circuit boards using compressed air, injury to the eyes could result from splashing solvent as it is removed from the printed circuit board. (p. 3-2)

There are exposed AC and DC connections inside the cabinet. These exposed electrical connections present a shock hazard that can cause injury or death. (p. 3-4)

If input or output circuits are a shock hazard after disconnecting system power at the power entry panel, then the door of the cabinet containing these externally powered circuits must be marked with a warning stating that multiple power sources exist. (p. 3-4)



Safety Summary (continued)

SPECIFIC CAUTIONS	Remove a module from its assigned slot before installing or removing a cable assigned to that slot. Failure to do so could result in damage to the module. (p. 2-4, 4-1)
------------------------------	--

Support Services



ABB will provide assistance in the operation and repair of its products. Requests for sales or application services should be made to your nearest sales or service office. ABB can also provide installation, repair and maintenance contract services.

When ordering parts, use nomenclature or part numbers and part descriptions from equipment manuals. Parts without a description must be ordered from the nearest sales or service office. Recommended spare parts lists, including prices are available through the nearest sales or service office.

ABB has modern training facilities available for training your personnel. On-site training is also available. Contact your nearest ABB sales office for specific information and scheduling.

Additional copies of this instruction, or other instructions, can be obtained from the nearest ABB sales office at a reasonable charge.



Trademarks and Registrations

Registrations and trademarks used in this document include:

® INFI 90 Registered trademark of Elsig Bailey Process Automation.

Preface



The NTFB01 Field Bus Termination Unit is a Harmony rack I/O device that is part of the Symphony Enterprise Management and Control System. It provides a communication link between 15 frequency shift keyed smart transmitters (or other smart devices) and an IMFEC11 Analog Input Module functioning in frequency shift keyed (FSK) field bus mode.

This instruction explains the NTFB01 termination unit specifications and operation. It details the procedures necessary to complete setup, installation, maintenance, repair, and replacement of the termination unit.

NOTE: The NTFB01 termination unit is fully compatible with existing INFI 90® OPEN Strategic Enterprise Management Systems.



List of Effective Pages

Total number of pages in this instruction is 30, consisting of the following:

Page No.	Change Date
Preface	Original
List of Effective Pages	Original
iii through viii	Original
1-1 through 1-5	Original
2-1 through 2-10	Original
3-1 through 3-4	Original
4-1 through 4-2	Original
Index-1	Original

NOTE: Changed text or tables are indicated by a vertical bar adjacent to the changed area. Changed figures are indicated by a vertical bar next to the figure caption. The date appears beside the page number.

Table of Contents



Section 1 Introduction	1-1
Overview	1-1
Intended User	1-2
Description	1-2
Mounting Hardware	1-2
Instruction Content.....	1-2
How to Use this Instruction	1-3
Document Conventions	1-3
Reference Documents.....	1-4
Related Nomenclature	1-4
Specifications.....	1-5
Section 2 Installation	2-1
Introduction.....	2-1
Special Handling.....	2-1
Unpacking and Inspection.....	2-2
Setup/Physical Installation	2-2
Mounting	2-2
Cable Connection	2-4
Power Wiring.....	2-5
Terminal Block Wiring	2-5
Star Field Bus	2-5
Linear Field Bus	2-6
Maximum Field Bus Length	2-7
Installation Complete	2-9
Section 3 Maintenance	3-1
Introduction.....	3-1
Preventive Maintenance Schedule.....	3-1
Equipment and Tools Required.....	3-1
Preventive Maintenance Procedures.....	3-2
Printed Circuit Board Cleaning	3-2
General Cleaning and Washing	3-3
Edge Connector Cleaning.....	3-3
Checking Connections.....	3-4
Section 4 Repair and Replacement	4-1
Introduction.....	4-1
Termination Unit Replacement	4-1



List of Figures

No.	Title	Page
1-1.	Harmony Rack I/O Architecture	1-1
1-2.	Mounting Hardware	1-3
2-1.	Termination Unit Installation	2-3
2-2.	Termination Unit Layout (Upper Circuit Board)	2-3
2-3.	Cable Connection	2-4
2-4.	Star Field Bus Connections	2-6
2-5.	Linear Field Bus Connections	2-6
2-6.	Maximum Total Field Bus Length (for Field Bus Module Communication)	2-7
2-7.	Maximum Total Field Bus Length (for STT02 Transmitter Communication)	2-8
2-8.	Example Star Field Bus	2-9
2-9.	Example Star and Linear Field Bus Combination	2-10

List of Tables

No.	Title	Page
1-1.	Reference Documents	1-4
1-2.	Related Nomenclature	1-4
1-3.	NTFB01 Termination Unit Specifications	1-5
3-1.	Preventive Maintenance Schedule	3-2
4-1.	Parts List	4-1

Safety Summary



Electrostatic Sensitive Device

Devices labeled with this symbol require special handling precautions as described in the installation section.

GENERAL WARNINGS

Equipment Environment

All components, whether in transportation, operation or storage, must be in a noncorrosive environment.

Electrical Shock Hazard During Maintenance

Disconnect power or take precautions to insure that contact with energized parts is avoided when servicing.

SPECIFIC WARNINGS

Verify the main power, field power, and power entry panel circuit breakers/switches are turned off before starting installation, retrofit, upgrade, or wiring procedures. Failure to do so could result in severe or fatal shock. Do not turn the power on until the installation, retrofit, upgrade, or wiring procedures are complete. (p. 2-5)

Never clean electrical parts or components with live power present. Doing so exposes you to an electrical shock hazard. (p. 3-2)

Wear eye protection whenever working with cleaning solvents. When removing solvents from printed circuit boards using compressed air, injury to the eyes could result from splashing solvent as it is removed from the printed circuit board. (p. 3-2)

There are exposed AC and DC connections inside the cabinet. These exposed electrical connections present a shock hazard that can cause injury or death. (p. 3-4)

If input or output circuits are a shock hazard after disconnecting system power at the power entry panel, then the door of the cabinet containing these externally powered circuits must be marked with a warning stating that multiple power sources exist. (p. 3-4)



Safety Summary (continued)

**SPECIFIC
CAUTIONS**

Remove a module from its assigned slot before installing or removing a cable assigned to that slot. Failure to do so could result in damage to the module. (p. 2-4, 4-1)

Support Services



ABB will provide assistance in the operation and repair of its products. Requests for sales or application services should be made to your nearest sales or service office. ABB can also provide installation, repair and maintenance contract services.

When ordering parts, use nomenclature or part numbers and part descriptions from equipment manuals. Parts without a description must be ordered from the nearest sales or service office. Recommended spare parts lists, including prices are available through the nearest sales or service office.

ABB has modern training facilities available for training your personnel. On-site training is also available. Contact your nearest ABB sales office for specific information and scheduling.

Additional copies of this instruction, or other instructions, can be obtained from the nearest ABB sales office at a reasonable charge.



Trademarks and Registrations

Registrations and trademarks used in this document include:

® INFI 90

Registered trademark of Elsig Bailey Process Automation.



Overview

The NTFB01 Field Bus Termination Unit is a Harmony rack I/O device that is part of the Symphony Enterprise Management and Control System. It provides a communication link between 15 frequency shift keyed (FSK) smart transmitters or other smart devices and an IMFEC11 Analog Input Module functioning in frequency shift keyed field bus mode.

Figure 1-1 shows the Harmony rack I/O architecture. A Harmony area controller and the Harmony rack controllers can use the rack I/O module and termination units for I/O interface.

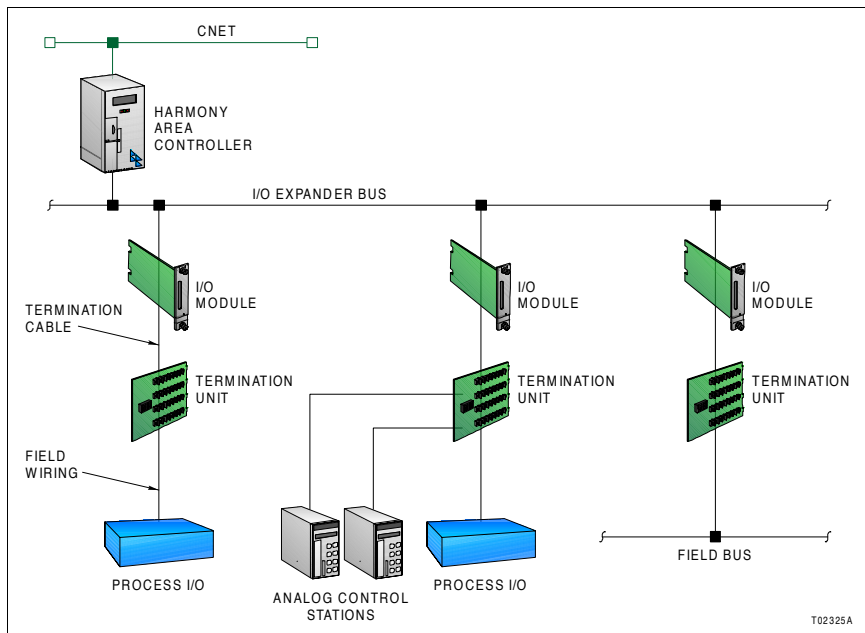

Figure 1-1. Harmony Rack I/O Architecture



Intended User

Personnel installing, operating, or maintaining the NTFB01 termination unit should read this instruction before performing any installation, operation, or maintenance procedures. Installation requires an engineer or technician with experience handling electronic circuitry. Those working with the NTFB01 termination unit should have experience working with and know the precautions to take around AC/DC power. A knowledge of the Symphony system and electronic principles is also required.

Description

The NTFB01 termination unit consists of two circuit boards. The lower circuit board contains electronic circuitry. The upper circuit board is attached to the lower circuit board with standoffs and a ribbon cable. It contains cable and wire connectors. The whole NTFB01 termination unit assembly contains:

- Four terminal strips.
- Three cable sockets.
- One power source Faston connector.
- One system common Faston connector.

Mounting Hardware

Harmony termination units mount in standard ABB Automation enclosures (CAB-01, CAB-04, CAB-12). A NFTP01 Field Termination Panel is used for termination unit mounting (Fig. 1-2). The panel attaches to the side rails in standard 438-millimeter (19-inch) enclosures.

Instruction Content

This instruction contains the following sections:

- Introduction** Provides an overview of the NTFB01 termination unit.
- Installation** Explains the physical installation, wiring and cable requirements, and handling of the termination unit.

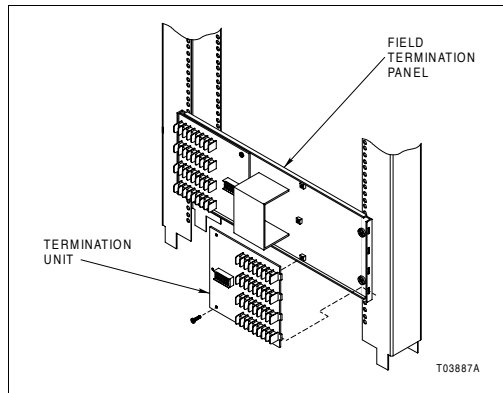

Maintenance Contains a maintenance schedule.

Repair and Replacement Explains how to replace the termination unit.

How to Use this Instruction

Read this instruction in sequence. It is important to become familiar with the entire contents of this instruction before using the termination unit. Refer to a specific section for information as needed.

1. Perform the steps in the installation section.
2. Refer to the maintenance section for scheduled maintenance requirements.
3. Refer to the repair and replacement procedures to replace a termination unit.

Document Conventions

The ? in the nomenclature or in a part number indicates a variable for that position (e.g., IMMFP1?).



Reference Documents

Table 1-1 lists ABB Automation instructions for equipment that is referenced in this instruction.

Table 1-1. Reference Documents

Number	Document
WBPEEUI200502??	Module Mounting Unit (IEMMU11, IEMMU12, IEMMU21, and IEMMU22)
WBPEEUI200505??	Site Planning Guidelines
WBPEEUI240764??	Analog Input module (IMFEC11)

Related Nomenclature

Table 1-2 lists nomenclature related to the NTFB01 termination unit.

Table 1-2. Related Nomenclature

Nomenclature	Description
IEMMU11, IEMMU12, IEMMU21, IEMMU22	Module mounting unit
IMFEC11	Analog input module
NFTP01	Field termination panel
NKSL01	Termination cable (PVC)
NKSL11	Termination cable (non-PVC)

Specifications

Refer to Table 1-3 for NTFB01 termination unit specifications.

Table 1-3. NTFB01 Termination Unit Specifications

Property	Characteristic/Value
Power requirements	+ 24 VDC 3.7 mA per transmitter typical 4.0 mA per transmitter maximum 85 mA per channel (shorted) maximum
Cable insulation PVC (UL rating PLTC) Non-PVC (UL rating PLTC)	80°C (176°F) at 300 V 90°C (194°F) at 300 V
Mounting	Mounts on the field termination panel.
Environmental	
Ambient temperature	0° to 70°C (32° to 158°F)
Relative humidity	5% to 95% up to 55°C (131°F) (noncondensing) 5% to 45% at 70°C (158°F) (noncondensing) Pollution degree: I
Altitude	Sea level to 3 km (1.86 mi)
Air quality	Noncorrosive
Cooling requirements	No cooling is required when used in ABB Automation cabinets and operated within environmental limits.
Surge protection	Meets IEEE-472-1974 surge withstand capability test.
Certifications	
Canadian Standards Association (CSA)	Certified for use as process control equipment in an ordinary (nonhazardous) location.
Factory Mutual (FM)	Approved as nonincendive equipment for use in Class I; Division 2; Groups A,B,C,D; hazardous locations.

SPECIFICATIONS ARE SUBJECT TO CHANGE WITHOUT NOTICE





Introduction

This section explains NTFB01 termination unit installation. Do **not** proceed with operation until the steps are read, understood, and performed in the order in which they appear.

Special Handling

Observe these steps when handling electronic circuitry:

1. **Use Static Shielding Bag.** Keep an assembly in its static shielding bag until ready to install it in the system. Save the bag for future use.
2. **Ground Bags before Opening.** Before opening a bag containing an assembly with static sensitive devices, touch it to the equipment housing or ground to equalize charges.
3. **Avoid Touching Circuitry.** Handle assemblies by the edges; avoid touching the circuitry.
4. **Avoid Partial Connection of Semiconductors.** Verify that all devices connected to the module are properly grounded before using them.
5. **Ground Test Equipment.**
6. **Use an Antistatic Field Service Vacuum.** Remove dust from assemblies if necessary.
7. **Use a Grounded Wrist Strap.** Use the ABB Automation field static kit (part number 1948385A1 - consisting of two wrist straps, ground cord assembly, alligator clip, and static dissipative work surface) when working with modules. The kit grounds a technician and the static dissipative work surface to the same ground point to prevent damage to the circuitry by electrostatic discharge. Connect the wrist strap to the appropriate grounding plug on the power supply or to an unpainted portion of the enclosure with the alligator clip. The wrist strap must be effectively connected to the earth grounding electrode system through the AC safety ground.



8. **Do Not Use Lead Pencils to Set Switches.** To avoid contamination of switch contacts that can result in unnecessary circuit board malfunction, do not use a lead pencil to set a switch.

Unpacking and Inspection

1. Examine the hardware immediately to verify it has not been damaged in transit.
2. Notify the nearest ABB sales office of any such damage.
3. File a claim for any damage with the transportation company that handled the shipment.
4. Use the original packing material and container to store the hardware.
5. Store the hardware in an environment of good air quality, free from temperature and moisture extremes.

Setup/Physical Installation

The NTFB01 termination unit is shipped ready to install. The termination unit mounts on a standard NFTP01 panel as shown in Figure 2-1. Figure 2-2 shows the layout of the termination unit upper circuit board.

Mounting

To mount the NTFB01 termination unit to the field termination panel:

1. Remove the safety shield.
2. Insert the tabs of the lower circuit board into the proper slots of the termination panel standoff and slide the circuit board into position.
3. Secure the lower termination unit circuit board to the field termination panel with two No. 10 thread-forming screws.

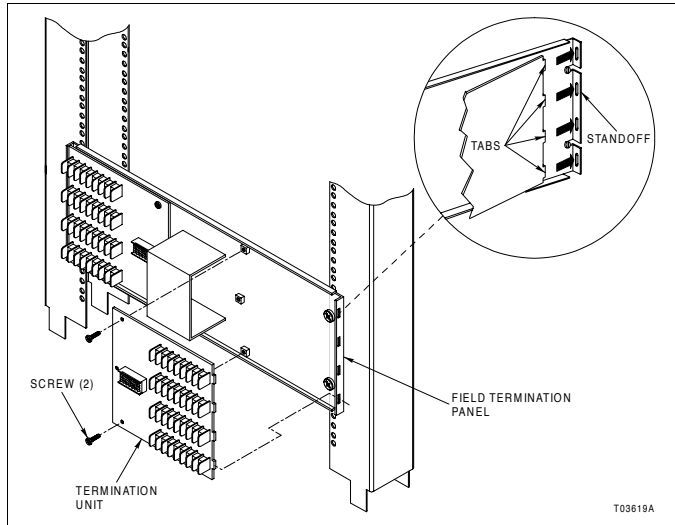

Figure 2-1. Termination Unit Installation

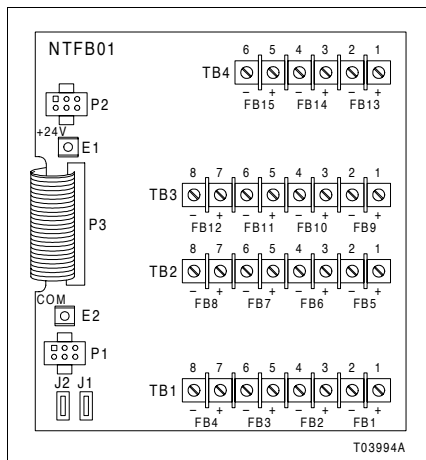

Figure 2-2. Termination Unit Layout (Upper Circuit Board)



Cable Connection

After mounting the termination unit to the field termination panel, install the NKSL01 or NSL11 termination cable. Figure 2-3 shows a diagram of cable connections to the I/O module and termination unit.

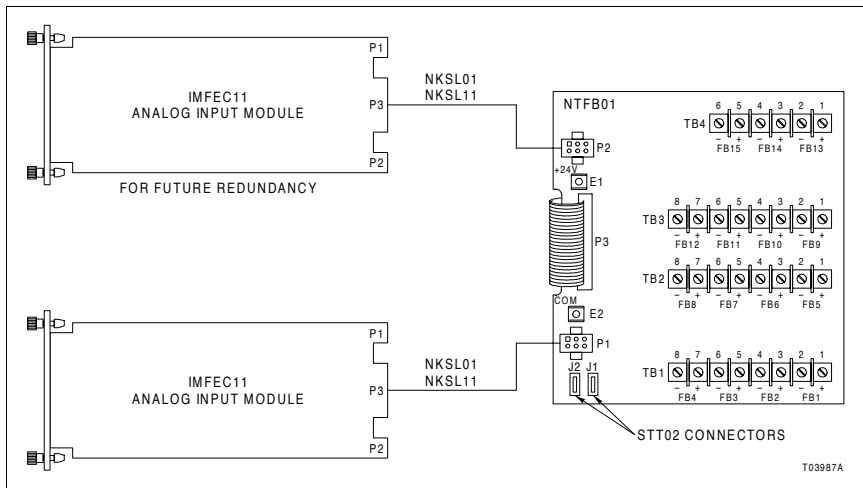

Figure 2-3. Cable Connection

To install the termination unit cable:

CAUTION

Remove a module from its assigned slot before installing or removing a cable assigned to that slot. Failure to do so could result in damage to the module.

1. Install the J1 connector of the NKSL01 or NKSL11 termination unit cable in the module mounting unit backplane slot assigned to the I/O module.
2. Insert the J2 connector of the cable into P1 of the termination unit.
3. If a redundant IMFEC11 module is being used, install a NKSL01 or NKSL11 cable from the redundant module to the P2 of the termination unit.

Power Wiring

There are two terminals that provide power and ground connections. Refer to Figure 2-2 for terminal locations. System power (+24 VDC) connects to the termination unit through Faston connector E1. System common (ground) connects through Faston connector E2.

To connect the power wiring:

WARNING

Verify the main power, field power, and power entry panel circuit breakers/switches are turned off before starting installation, retrofit, upgrade, or wiring procedures. Failure to do so could result in severe or fatal shock. Do not turn the power on until the installation, retrofit, upgrade, or wiring procedures are complete.

1. Attach a 14 AWG wire from the +24 VDC power source to the E1 terminal on the termination unit.
2. Attach a 14 AWG wire from the system ground to the E2 terminal of the termination unit.

Terminal Block Wiring

There are two ways of connecting field bus transmitters to the NTFB01 termination unit. The two methods available are the star field bus and linear field bus. Either method can use single or two channel inputs. Two channel inputs are inputs that have two channels tied together in parallel. The two channel input reduces channel loss, but also reduces the number of inputs by half on a star field bus. Do not connect more than two channels together on the termination unit.

Refer to Figure 2-2 for terminal block assignments and terminal polarity. Refer to the **Site Planning Guidelines** instruction for specific information on field wiring installation requirements (i.e., spacing, isolation, etc.). Connect the wiring from the input devices to the terminals.

Star Field Bus

When using a star field bus, each transmitter is individually wired to the termination unit. The NTFB01 termination unit



can drive a maximum of 10 transmitters in the star field bus configuration. Figure 2-4 shows an example of a star field bus.

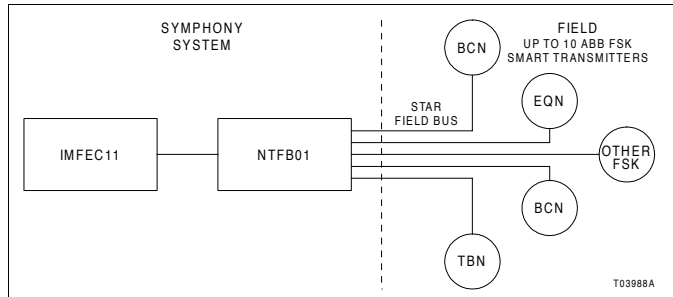

Figure 2-4. Star Field Bus Connections

Linear Field Bus

When connecting a series of field bus transmitters on a linear field bus, a single continuous line (i.e., wire) connects the transmitters on the bus. The NTFB01 termination unit can drive a maximum of 15 transmitters in a linear field bus configuration. Figure 2-5 shows an example of field wiring in a linear field bus.

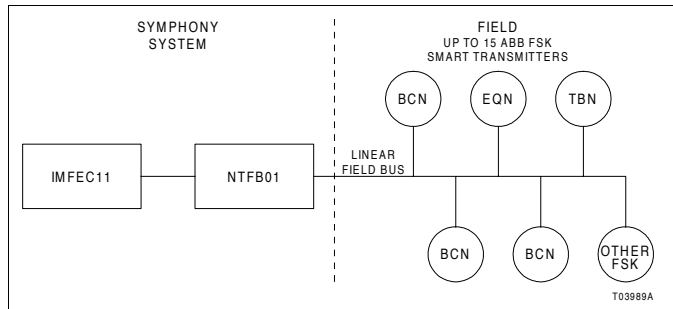

Figure 2-5. Linear Field Bus Connections

Maximum Field Bus Length

All field wiring to the field bus termination unit must comply with the following.

1. The total length of field bus wire for a given number of transmitters must not exceed the length specified in Figure 2-6 for termination unit to transmitter communication. Figure 2-7 applies to smart transmitter terminal to transmitter communication when the Type STT02 Smart Transmitter Terminal is connected to the termination unit.

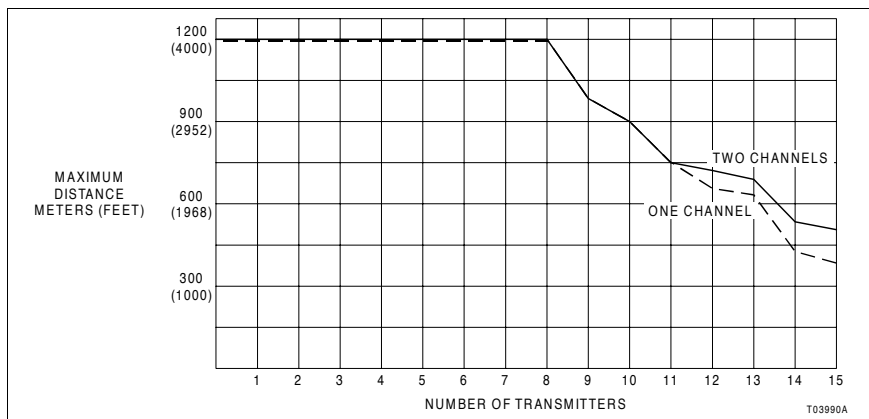

Figure 2-6. Maximum Total Field Bus Length (for Field Bus Module Communication)

2. Virtually any combination of field bus type/transmitter can be used as long as the requirements in Step 1 are met.

Example If there are five transmitters connected to the NTFB01 termination unit on a star field bus, the total maximum length of the field bus is 1200 meters. The wire for each of the five transmitters can be any length provided the total length of wire does not exceed 1200 meters. Thus two transmitters could be 100 meters from the termination unit, two could be 250 meters from the termination unit, and the last transmitter 500 meters from the termination unit.

$$2(100 \text{ meters}) + 2(250 \text{ meters}) + 500 \text{ meters} = 1200 \text{ meters maximum}$$

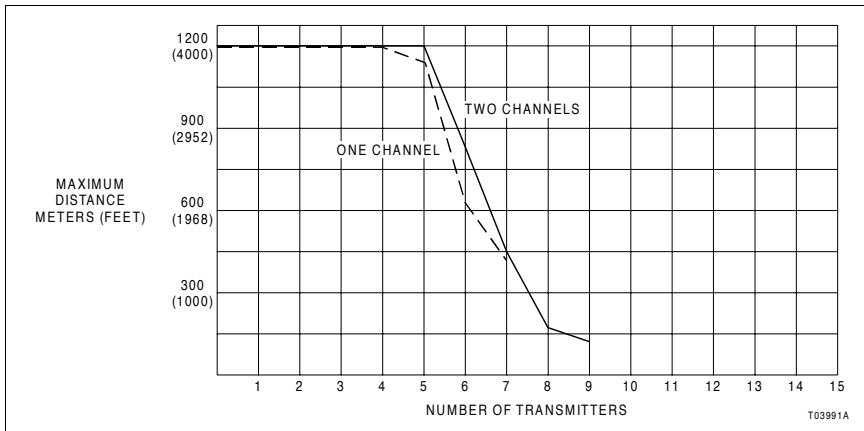

Figure 2-7. Maximum Total Field Bus Length (for STT02 Transmitter Communication)

Figure 2-8 shows an example of single channel inputs on a star field bus with various lengths of wire on each point of the star field bus. Figure 2-9 shows an example of 12 transmitters using two channel inputs. This configuration is a linear field bus and star field bus using the same termination unit with branches at various lengths. The total length of all buses does not exceed the maximum allowable length.

3. Use 18 AWG wire or larger. The wire can be unshielded or shielded.

NOTE: Using wire less than 18 AWG decreases the maximum bus lengths allowed.

4. The data on communication lengths for the Type STT02 Smart Transmitter Terminal (Fig. 2-7) applies when the STT02 terminal is connected to the termination unit and communicating to a transmitter on the field bus. When the smart transmitter terminal is connected to a transmitter and communicating to a transmitter on another branch of a star field bus, these communication lengths may be lower.

NOTE: The maximum bus lengths shown in Figures 2-6 and 2-7 are maximum bus lengths without intrinsic safety barriers.

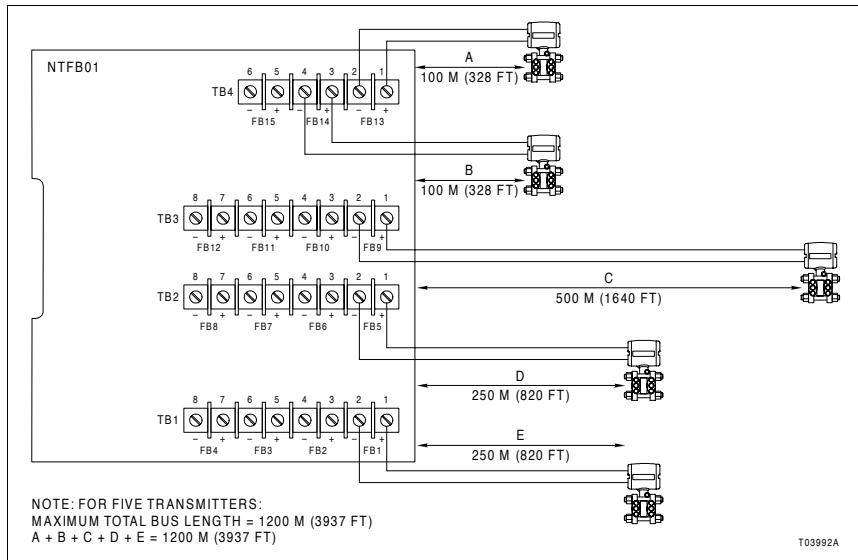

Figure 2-8. Example Star Field Bus

Do not mix one channel inputs and two channel inputs on the same termination unit. Whenever any termination unit is wired for two channel input, all inputs to that particular termination unit must be wired for two channel input. If a termination unit is wired for one channel input, all inputs to that particular termination unit must be wired for one channel input.

Installation Complete

The termination unit is ready for operation when:

1. The termination unit is installed on the field termination panel.
2. The cables are connected.
3. Power wiring is connected and applied to the termination unit.

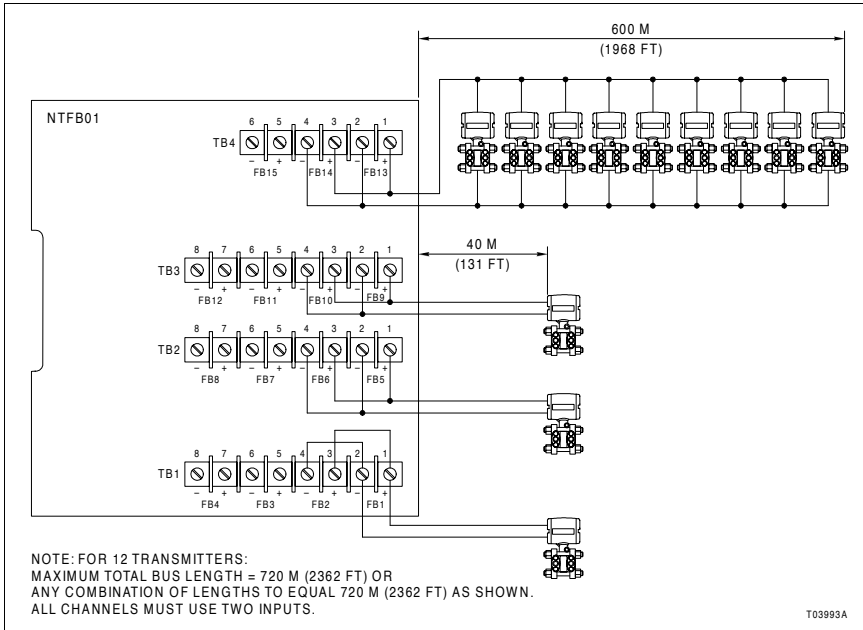

Figure 2-9. Example Star and Linear Field Bus Combination

4. Terminal block wiring is connected to the termination unit and field device.
5. The safety shield is installed.



Introduction

The reliability of any stand-alone product or control system is affected by the maintenance of the equipment. ABB Automation recommends that all equipment receive preventive maintenance to keep the equipment operating at an optimum level.

This section presents procedures that the customer should be able to perform on site. These preventive maintenance procedures should be used as a guideline to assist in establishing good preventive maintenance practices.

Personnel performing preventive maintenance should meet the following qualifications.

- Personnel should be qualified electrical technicians or engineers that know the proper use of test equipment.
- Personnel should be familiar with the module mounting unit and field termination panel, have experience working with process control systems, and know what precautions to take when working on live AC and/or DC systems.

Preventive Maintenance Schedule

Table 3-1 is the preventive maintenance schedule for the NTFB01 termination unit. The table lists the preventive maintenance tasks in groups according to their specified maintenance interval. Tasks that require further explanation are covered under **Preventive Maintenance Procedures**.

NOTE: The preventive maintenance schedule is for general purposes only. Your application may require special attention.

Equipment and Tools Required

Tools and equipment required for maintenance procedures:

- Antistatic vacuum.
- Screwdriver (medium length).



Table 3-1. Preventive Maintenance Schedule

Task	Frequency
Check cabinet air filters. Clean or replace them as necessary. Check the air filter more frequently in excessively dirty environments.	3 months
Check cabinet and termination unit for dust. Clean as necessary using an antistatic vacuum.	
Check all termination unit signal, power and ground connections within the cabinet. Verify that they are secure. Refer to procedure.	
Check termination unit circuit board, giving special attention to power contacts and edge connectors. Clean as necessary. Refer to procedure.	12 months
Complete all tasks in this table.	Shutdown

- Isopropyl alcohol (99.5 percent electronic grade).
- Distilled water.
- Compressed air.
- Foam-tipped swabs.
- Lint-free cloths.
- Nonabrasive eraser.

Preventive Maintenance Procedures

This section covers tasks from Table 3-1 that require specific instructions or further explanation.

- Cleaning printed circuit boards and edge connectors.
- Checking signal, power and ground connections.

Printed Circuit Board Cleaning

WARNING

Never clean electrical parts or components with live power present. Doing so exposes you to an electrical shock hazard.

Wear eye protection whenever working with cleaning solvents. When removing solvents from printed circuit boards using compressed air, injury to the eyes could result from splashing solvent as it is removed from the printed circuit board.

There are several circuit board cleaning procedures in this section. These procedures cover circuit board cleaning and washing, cleaning edge connectors and circuit board laminate between edge connectors. Use the procedures that meet the

needs of each circuit board. Remove all dust, dirt, oil, corrosion or any other contaminant from the circuit board.

Perform all cleaning and handling of the printed circuit boards at static safe work stations. Always observe the steps under ***Spectral Handling*** in Section 2 when handling printed circuit boards.

General Cleaning and Washing

If the printed circuit board needs minor cleaning, remove dust and residue from the printed circuit board surface using clean, dry, filtered compressed air or an antistatic field service vacuum cleaner.

To wash the printed circuit board:

1. Clean the printed circuit board by spraying or wiping it with isopropyl alcohol (99.5% electronic grade). Use a foam-tipped swab to wipe the circuit board.
2. Remove excess solvent by using compressed air to blow it free of the circuit board.

Edge Connector Cleaning

1. Use a solvent mixture of 80% isopropyl alcohol (99.5% electronic grade) and 20% distilled water.
2. Soak a lint-free cloth with the solvent mixture.
3. Work the cloth back and forth parallel to the edge connector contacts.
4. Repeat with a clean cloth that is soaked with the solvent mixture.
5. Dry the edge connector contact area by wiping with a clean lint-free cloth.

To clean tarnished or deeply stained edge connector contacts:

1. Use a nonabrasive eraser or equivalent to remove tarnish or stains. Fiberglass or nylon burnishing brushes may also be used.
2. Minimize electrostatic discharge by using the 80/20 isopropyl alcohol/water solution during burnishing.



3. Do not use excessive force while burnishing. Use only enough force to shine the contact surface. Inspect the edge connector after cleaning to assure no loss of contact surface.
4. Wipe clean with a lint-free cloth.

Checking Connections

NOTE: Power to the cabinet should be off while performing this preventive maintenance task.

WARNING

There are exposed AC and DC connections inside the cabinet. These exposed electrical connections present a shock hazard that can cause injury or death.

If input or output circuits are a shock hazard after disconnecting system power at the power entry panel, then the door of the cabinet containing these externally powered circuits must be marked with a warning stating that multiple power sources exist.

Check all signal wiring, power and ground connections within the cabinet to verify their integrity. When checking connections, always turn a screw, nut or other fastening device in the direction to tighten only. If the connection is loose, it will be tightened. If the connection is tight, the tightening action will verify that it is secure. There must not be any motion done to loosen the connection.

1. Verify that all power connections within the cabinet are secure.
2. Verify that all wiring connections to the termination unit are secure.



Introduction

This section explains the repair and replacement procedures for a NTFB01 termination unit. Table 4-1 is a replacement and spare parts list.

Table 4-1. Parts List

Part Number	Description
NFWAB17010	0.19-16 (no.10) x 5/8 in. Phillips-head thread forming screw

Termination Unit Replacement

If it is determined that the termination unit is faulty, replace it with a new one. **Do not** try to repair the unit; replacing components may affect the unit performance and certification. When replacing a termination unit, observe the special handling guidelines listed in [Section 2](#).

NOTE: Turn off power to the field devices before removing the cables from the termination unit.

CAUTION Remove a module from its assigned slot before installing or removing a cable assigned to that slot. Failure to do so could result in damage to the module.

Follow Steps 1 through 13 to replace the termination unit.

1. Turn off power to the cabinet and remove the safety shield.
2. Disconnect the power source and ground wiring from the E1 and E2 Faston connectors of the termination unit. Mark the wires according to their terminal assignment as they are removed.
3. If the termination unit is connected to I/O modules, pull the I/O modules out of their cable connections on the module mounting unit backplane.



4. If there are termination cables connected, disconnect them from the connectors on the termination unit. Mark the cables according to their connector assignments as they are removed.
5. Turn off power to the field devices. Disconnect I/O wiring from the terminal blocks. Mark the wires according to their terminal assignment.
6. When all cables and wires are removed from the termination unit, remove the two mounting screws and remove the termination unit from the field termination panel.
7. Secure the replacement termination unit circuit board to the field termination panel with the two mounting screws.
8. Connect the termination unit cables to their assigned connector on the termination unit.
9. Connect the I/O wiring to the terminal strips.
10. Connect the power source and ground wiring to the E1 and E2 Faston connectors of the termination unit.
11. Push on the faceplate of the I/O modules to fully insert them into their module mounting unit slots. The I/O modules should be seated in the termination unit cable at the rear of the module mounting unit when fully inserted.
12. After all cables and wiring have been replaced, install the safety shield and return power to the field devices.
13. Return power to the cabinet.



C	N
Checking connections 3-4	Nomenclature 1-4
Cleaning	O
Edge connectors 3-3	Overview 1-1
Printed circuit boards 3-2	P
Conventions, documents 1-3	Parts list 4-1
F	PCB cleaning 3-2
Field bus wiring lengths 2-7	Power wiring 2-5
Field static kit 2-1	Preventive maintenance
H	Checking connections 3-4
How to use this instruction 1-3	Schedule 3-1
I	Tools and equipment 3-1
I/O wiring 2-5	S
Installation	Setup/physical installation 2-2
Cables 2-4	Special handling 2-1
I/O wiring 2-5	Star field bus 2-5
Power wiring 2-5	T
L	Termination unit
Linear field bus 2-6	Cables 2-4
M	Mounting 2-2
Maintenance 3-1	Replacement 4-1
Schedule 3-1	U
Tools required 3-1	Unpacking and inspection 2-2
Mounting hardware 1-2	User qualifications 1-2



*For the latest information on ABB and Year 2000 Product Compatibility
Visit us on the World Wide Web at <http://www.abb.com>*

Our worldwide staff of professionals is ready to meet *your* needs for process automation.
For the location nearest you, please contact the appropriate regional office.

Americas

29801 Euclid Avenue
Wickliffe, Ohio USA 44092
Telephone 1-440-585-8500
Telefax 1-440-585-8756

Asia/Pacific

539 Yishun Industrial Park A
Singapore 768740
Telephone 65-756-7655
Telefax 65-756-7309

Germany

Industriestrasse 28
D-65760 Eschborn
Germany
Telephone 49-6196-800-0
Telefax 49-6196-800-1119

Europe, Africa, Middle East

Via Puccini 2
16154 Genoa, Italy
Telephone 39-010-6584-943
Telefax 39-010-6584-941

